



G I N

YETI Rescue Parachute Owner's Manual



Please read this manual prior to installing the Yeti rescue parachute into your harness.

Thank You...

Thank you for choosing the YETI Rescue parachute. This manual contains all the information you need to know to re-pack, deploy, and maintain your rescue parachute. A thorough knowledge of your equipment will keep you safe and enable you to maximize your full potential.

Please pass on this manual to the new owner if you do resell your rescue parachute.

Happy Flights and Safe Landings,

The GIN Team

Safety Notice

By purchasing our equipment, you take full responsibility for being a certified paraglider pilot and you accept all risks inherent with paragliding or Speed gliding activities including injury and death. Improper use or misuse of GIN equipment greatly increases these risks. Neither Gin Gliders Inc nor the seller of GIN equipment shall be held liable for personal or third party injuries or damages under any circumstances. If any aspect of the use of our equipment remains unclear, please contact your local GIN reseller or importer in your country.

1. Introducing the YETI rescue parachute

The YETI Rescue was developed by the R&D team of Gin Gliders to meet the highest safety standards and to provide an ultra light weight of the most demanding pilots - the YETI Rescue is the rescue used by GIN test pilots during the development of new paragliders and speed gliders.

The YETI Rescue is a pulled down apex Parabolic type reserve parachute. This design offers the optimal combination of fast opening time, low descent rate, stability, compact size and ultra light weight

The YETI Rescue is designed only for use in an emergency situation on a paraglider and speedglider; it is unsuitable for free fall parachuting.

Certification

The YETI Rescue is EN certified (EN12491-2001).



Conformity tests according to **EN 12491:2001**
Conformity number **EP 019.2009**

MANUFACTURER _____ **GIN GLIDERS**
MODEL _____ **Yeti # 35**
YEAR AND MONTH OF
MANUFACTURE
MAXI LOAD WEIGHT IN FLIGHT _____ **100 kg**
FLAT AERA _____ **34.1 m²**
WEIGHT OF THE MODEL _____ **1539gr**
TOTAL LENGHT (end of the riser
to canopy top uninflated) _____ **530 cm**

**Warning: not suitable for use at speeds in excess
of 32 m/s (115 km/h)
Before use referto the user's manual.**

Serial number:
Conformity tests according to **EN 12491:2001** standards carried out by:

para-test.com



Air Turquoise SA
Rte du Pré-au-Comte 8 | CH-1844 Villeneuve
tel. +41 21 965 65 65 | mobile +41 79 202 52 30
info@para-test.com

Description

Description	Pull Down Apex Parabolic type Rescue Parachute		
	#27	#35	#40
Size	#27	#35	#40
Area	27 m ²	35 m ²	40 m ²
No. of Gores	16	18	20
Line Length	4.71 m	5.3 m	5.7 m
Centere line	5.24 m	5.89 m	6.34 m
Weight	1.25 kg	1.5 kg	1.75 kg
Sink Rate (at Max. Load)	5.067 m/s	5.034 m/s	5.13 m/s
Maximum Load	80 kg	100 kg	120 kg
Opening time	3.24 s	3.04 s	3.16 s
Certification	EN	EN	EN

2. Packing Instructions

Gin Gliders YETI rescue parachutes are inspected and packed at the factory. It is recommended that the reserve is repacked by a suitably qualified and experienced paragliding professional or parachute rigger prior to installation into your harness. The efficacy of the rescue, and your life, depend on the correct packing procedure. If in any doubt whatsoever, please seek professional advice from your instructor, GIN dealer or importer.

Airing

Before packing, the canopy should be aired. Ideally, the canopy should be hung by its apex from the ceiling for 24 hours in a cool, dry room.

Preparation

The packing area must be spacious, clean, smooth and dry.

Preliminary Materials

Before starting the packing procedure, make sure you have the following materials:

- Yeti rescue inner bag

- Rubber bands (to change at each re-packing)

- 2 lengths of thin cord to aid closing the inner deployment bag (Don't use Kevlar line, and the end of lines should not be cut by heat.)

- 2 solid weights or sandbags, which should be smooth and clean (2-2.5kg)

- 2 pins

- Line separator

Layout

Check the serial number that is written on the top centre panel and on the re-packing card first (re-packing card is attached at the end of this manual).

Fix the risers to a solid point using carabiners.



Line Check

Stretch the rescue out to its full length. Check the suspension lines for damage and tangles by the "4 lines check" method.

All lines should be located inside the 4 lines – first and last lines at both sides from the bridles as illustrated below.

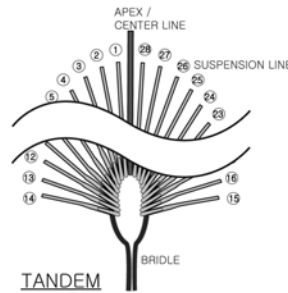
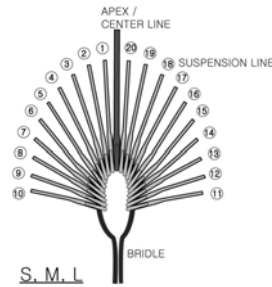
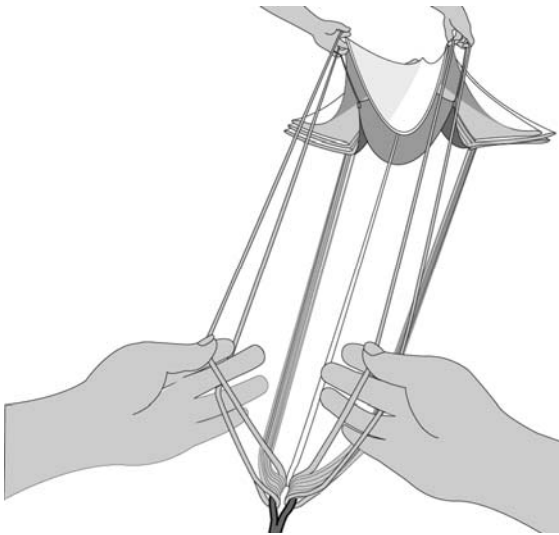

Folding the Panels

Check that all the apex lines are the same length.

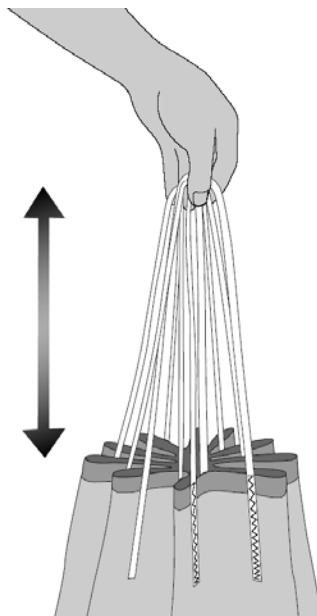

Put the suspension lines on the line separator such that half of them are on the left, and half are on the right. Put a weight on the skirt to fix the canopy.

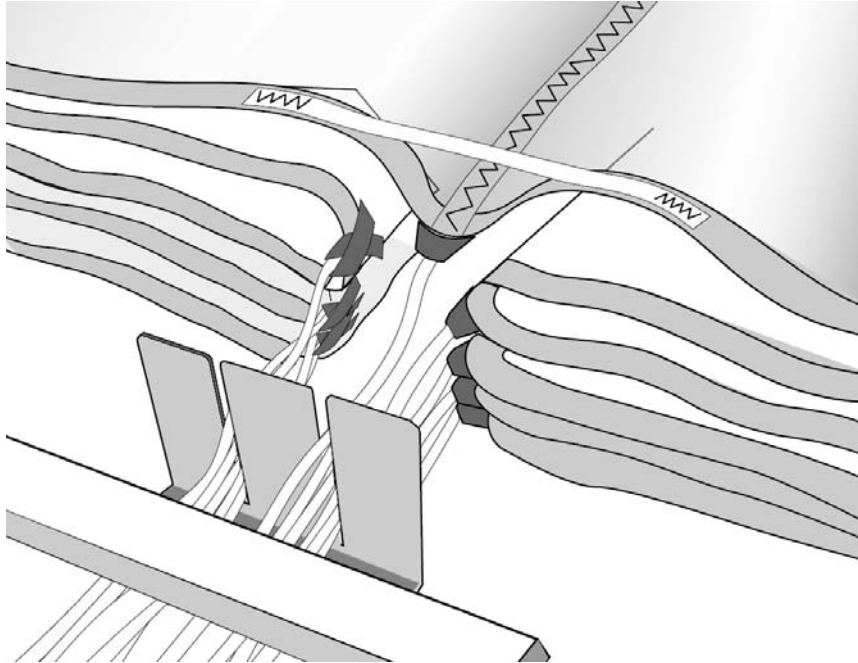

And follow the outer suspension line to find the centre panels to start folding with.

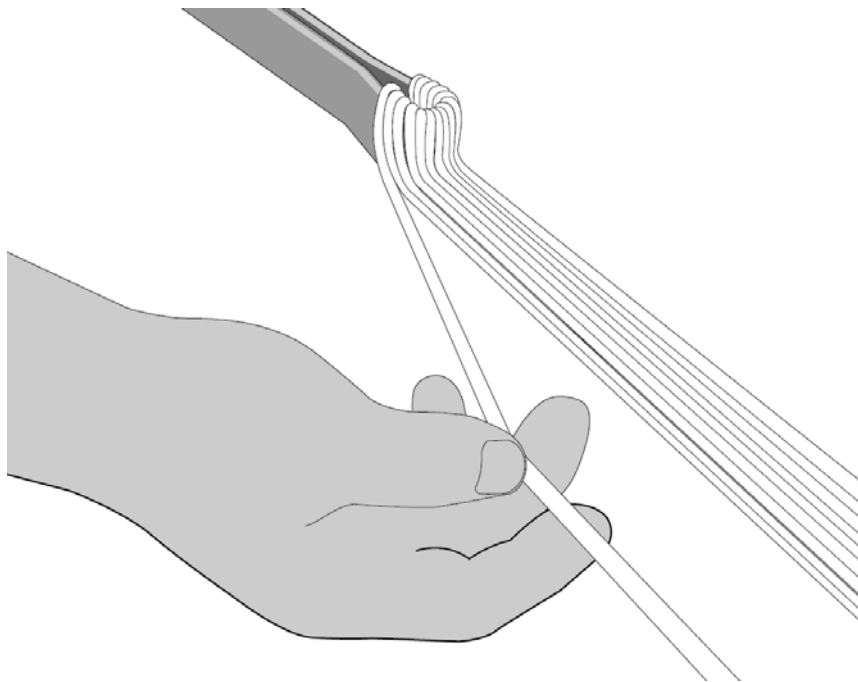

Dividing the Panels

First fold all the panels one by one to the right side of the suspension lines, to prepare for the careful folding. While doing this, check for any signs of damage or deterioration of the canopy fabric.

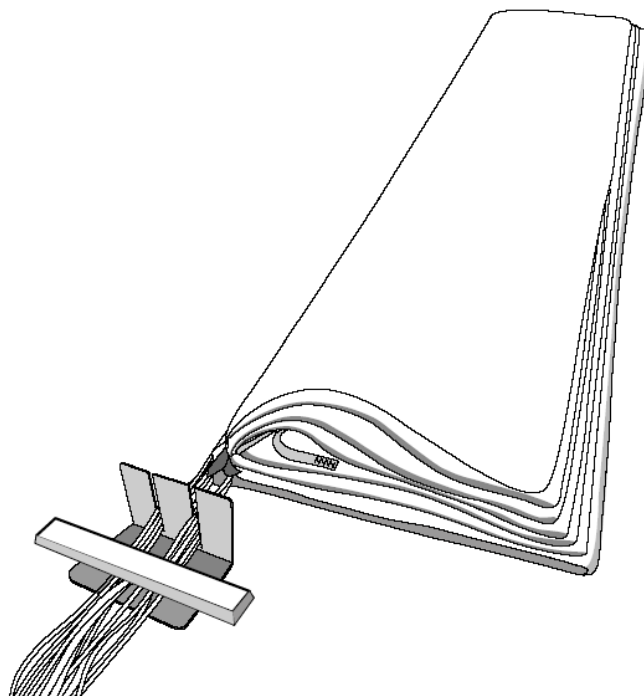
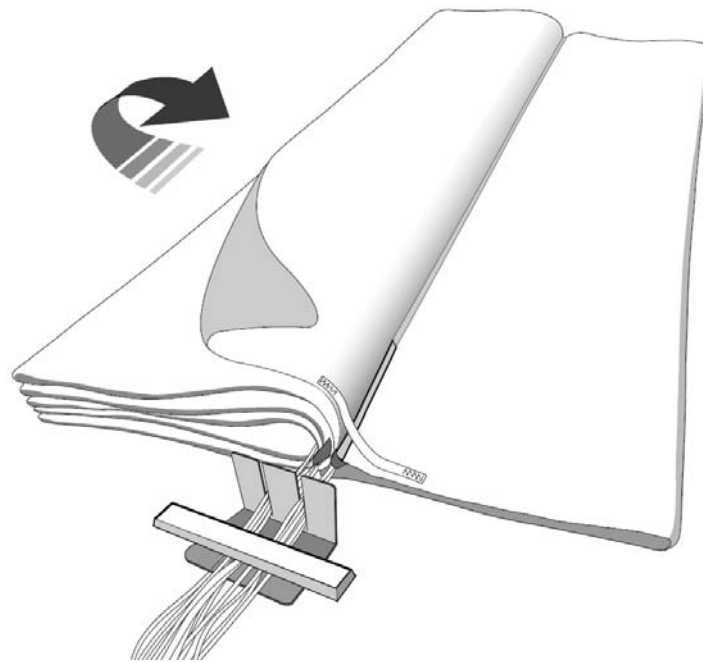

By folding each panel to the left side of the suspension lines again one by one, check carefully that each panel is laid evenly and without creases. Check the centre seams and inside the panels, too.

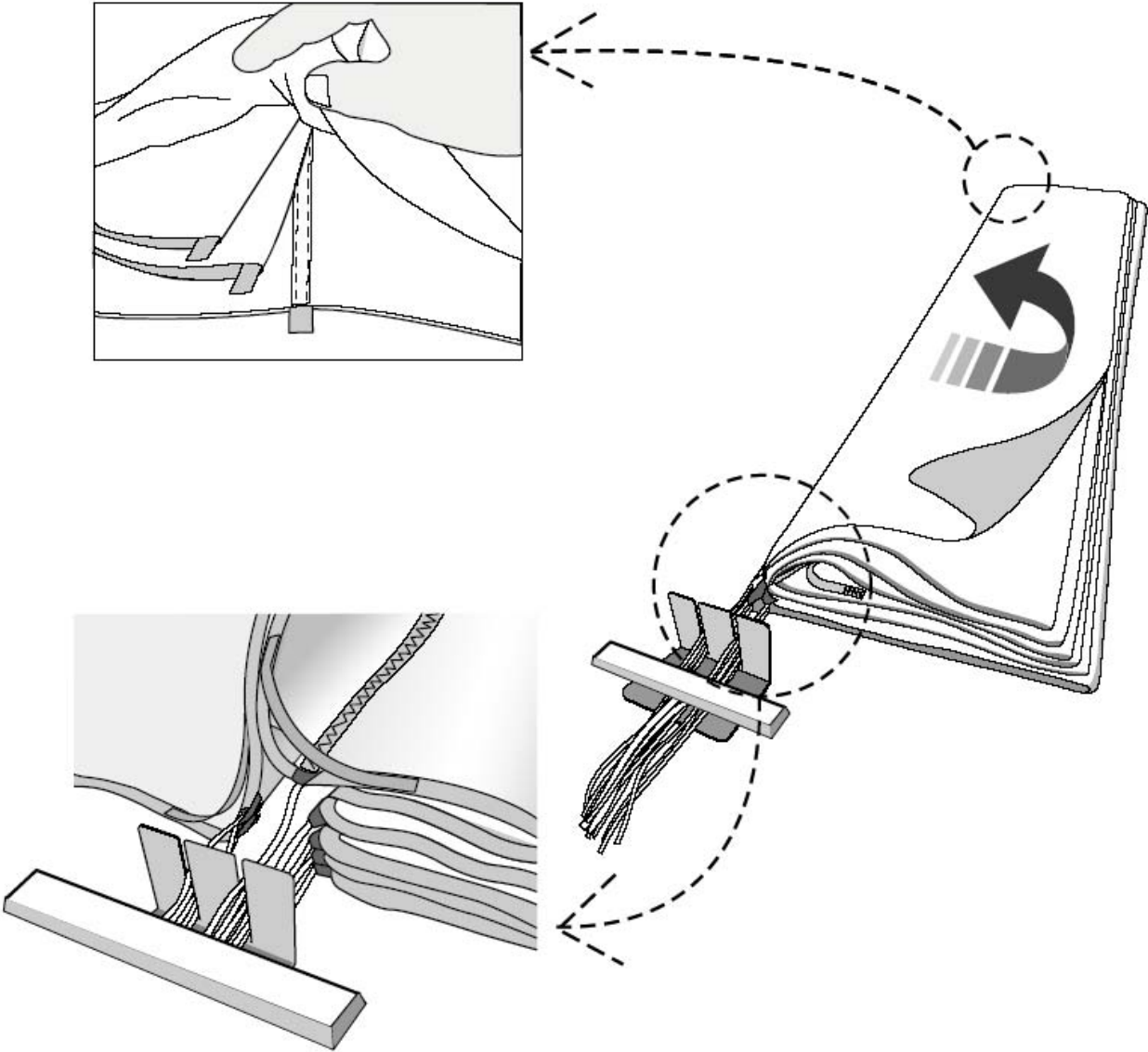

Make sure that all the skirts are even and all the loops lie in the same direction.

After you finish the left half, do the same for the right half of the canopy. Move the rest of the right half to the left, and fold each panel one by one to the right side of the suspension lines. Check the same carefully that each panel is laid evenly and without creases. Check the centre seams and inside the panels, too.

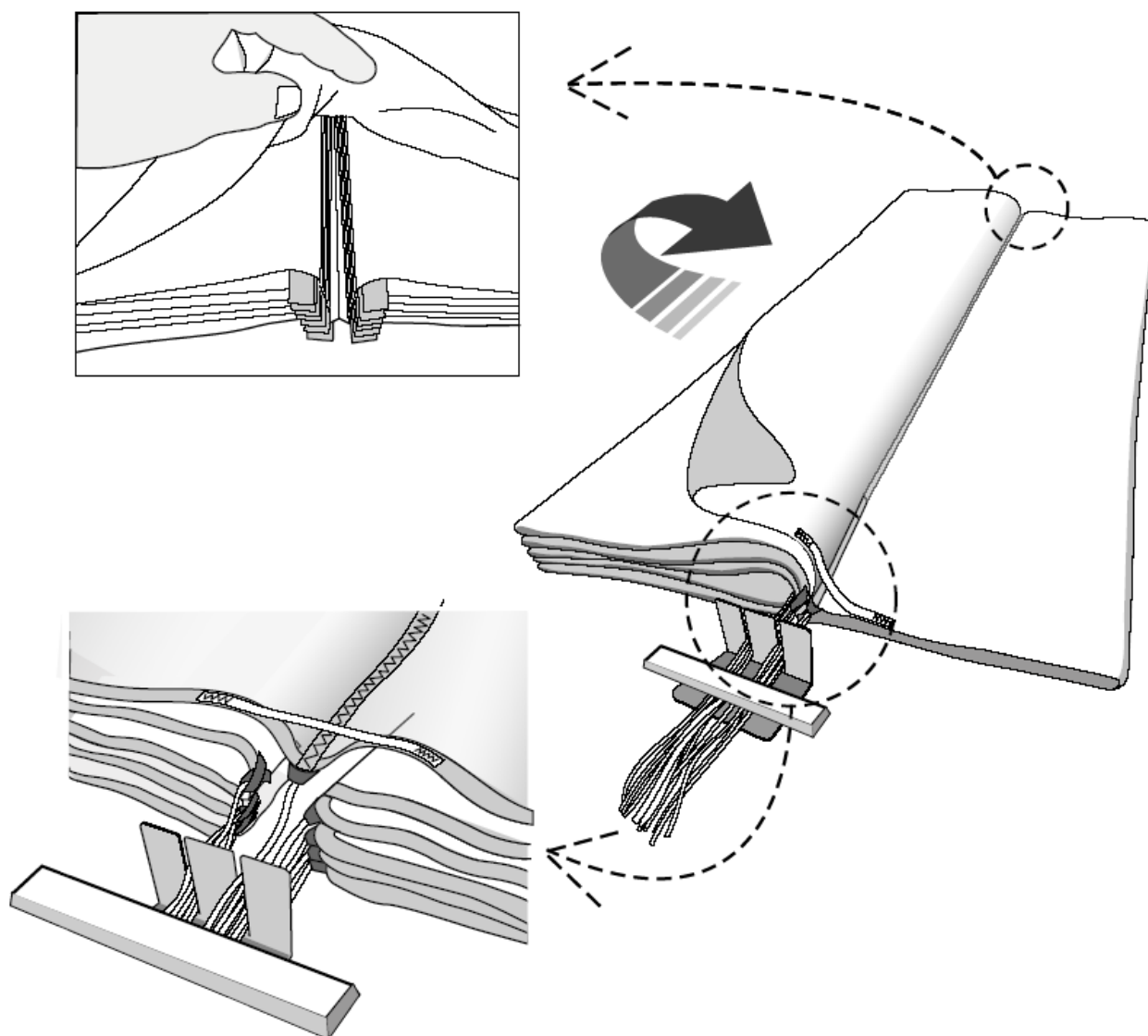

After folding all the panels, check again that the centre seams and the inside of the panels are even and lie in the same direction.

S-Folding

Fold 1/3 of the canopy from the left, and fold another 1/3 from the right side. Then, fold the right half of the canopy onto the left. Fold so that the width of the canopy is the same from the top of the canopy to the skirt (bottom).

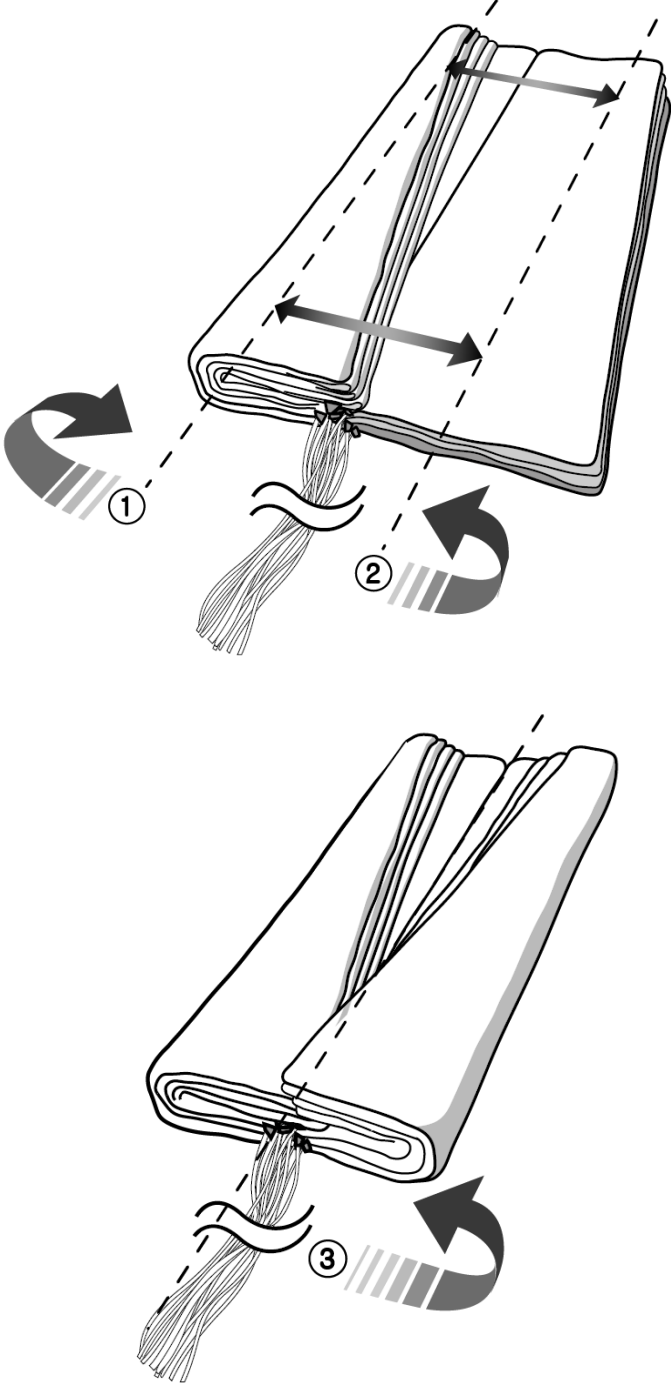

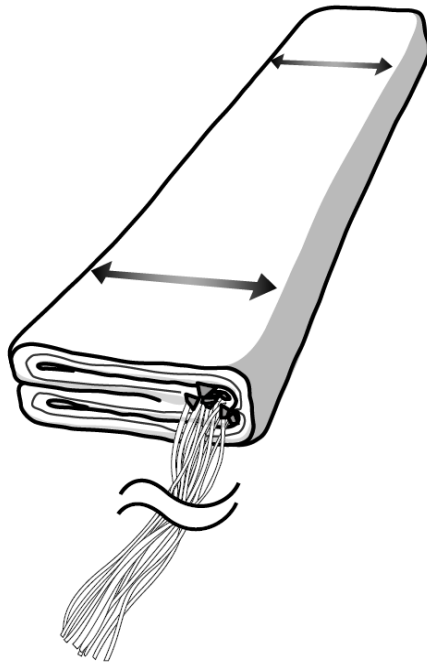

Fold the canopy in an accordion or "S" shaped fold, so that it fits into the inner deployment bag. If possible, adjust the folds so that those at the skirt are slightly shorter and those at the top of the canopy are slightly longer. The YETI rescue fits well if there are 8 folds.

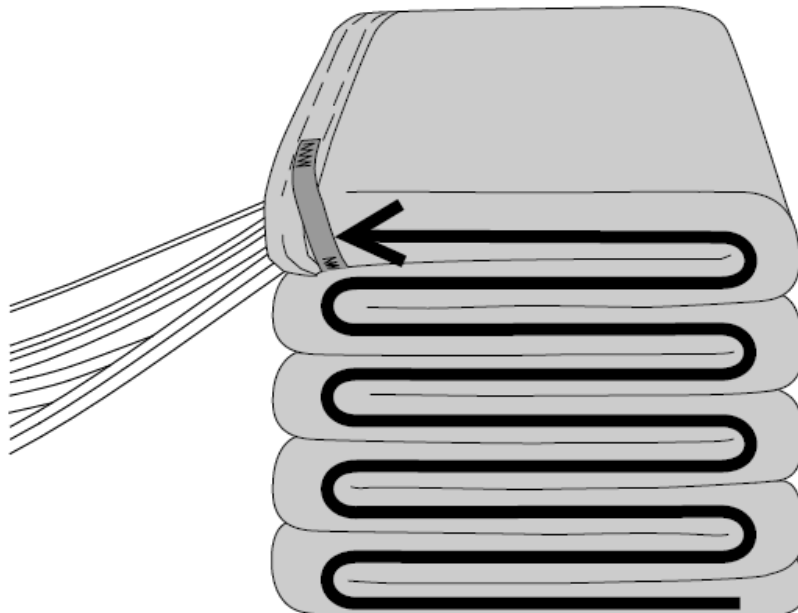

Packing into Inner Deployment Bag

Stow the canopy so that the skirt is on top of the folds in the deployment bag.

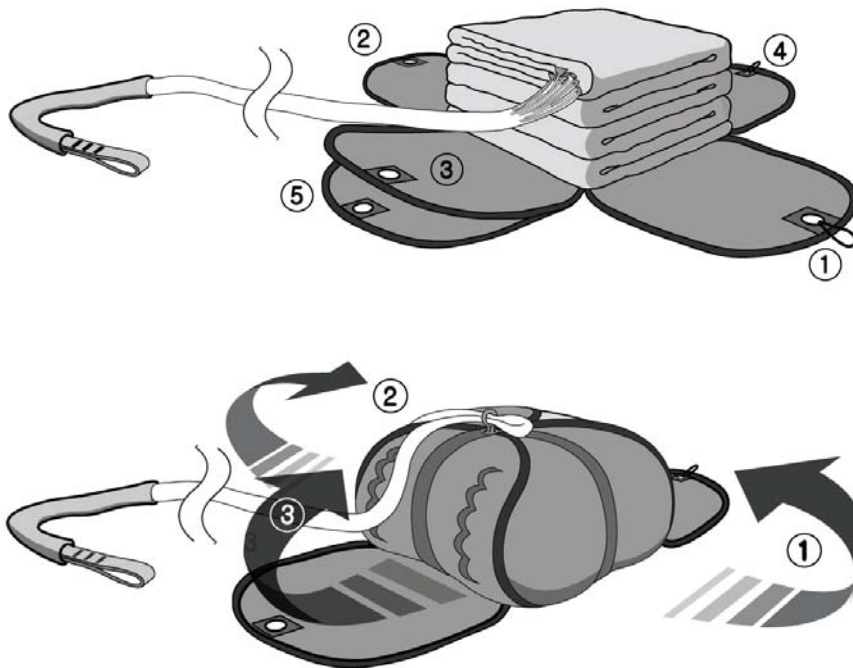

Stowing the lines

First close the flaps 1, 2 and 3 of the deployment bag with a bite (3cm loop) of lines through the elastic closing loop. Start to stow the suspension lines making sure you keep equal tension on all lines. Lay the upper suspension lines in between the flaps 3 and 5 of the deployment bag.

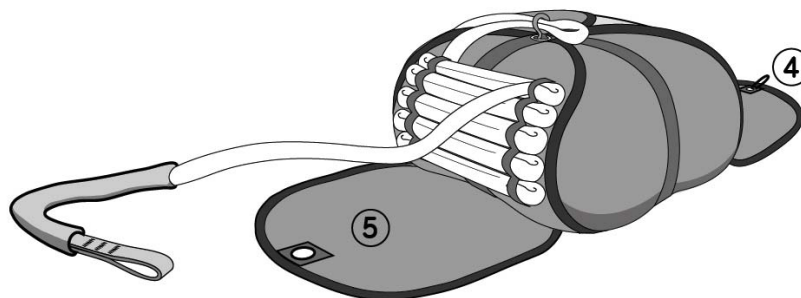

Now, stow the suspension lines in a 'figure of 8' pattern, fixing pairs of '8's with the rubber bands attached at the flap no. 3 of the deployment bag at each end of the '8'. **SUSPENSION LINES SHOULD ALWAYS HAVE EQUAL TENSION!**

Closing the deployment bag

Thread the elastic closing loop attached to the deployment bag through the eyelets of the last two flaps, numbers 4 and 5 as well, and place a bight (3cm loop) of suspension lines through the elastic closing loop. The last 50-70cm of the lines is left free. Make sure that each bight (loop) of lines is clear and that nothing can interfere or obstruct the loops.

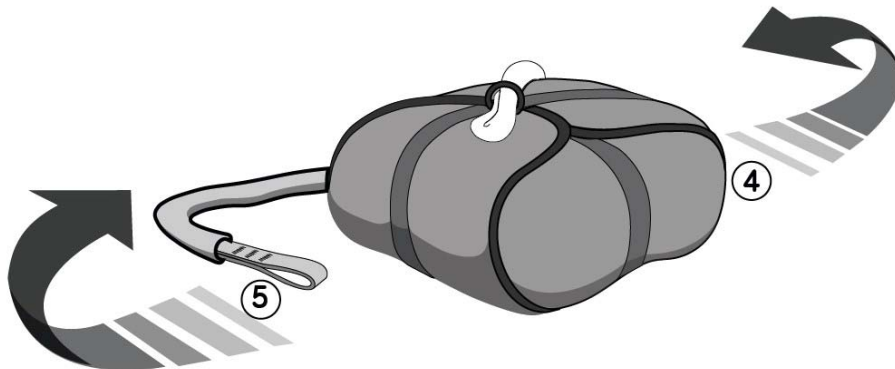

Test

Lifting the bridle, check the force required to allow the lines to free themselves from the closing loop of the deployment bag. This force should be around 200g. This force may be verified with a spring balance, if available.

3. Installation into harness

Installation into harness and compatibility check

The YETI rescue is compatible with GIN harnesses. It may also be compatible with almost all other manufacturer's harnesses and can be installed in their integrated rescue containers. To be sure it really functions, always get an expert to make the first installation into the harness for you. After the installation you must do a compatibility check yourself. Sit in your harness in a harness simulator and check if you can release the rescue from the container in the harness.

Attaching the rescue using an outer container

The Yeti rescue can be attached to a harness which does not have an integrated rescue container (such as the GIN Basis or Speed glider harness), using an optional outer container for the Yeti rescue. If in doubt, consult with a professional..

Attaching the rescue bridle to the harness webbing

A suitable screw gate connector should be used, for example; a 7mm, square, Stainless Steel maillon, *But in any case, the connector must have a minimum strength of at least 9 times the total suspended weight.*

The maillon should be held in place with rubber bands, tape or plastic heat sealed tube.

Webbing to webbing connections are not recommended, due to the danger of getting the knot the wrong way round, which significantly weakens it.

GIN gliders supply the "Y" bridle by the option what you need extensional length of bridle.



Attaching the rescue deployment bag to the harness deployment handle

Most harnesses come with their own deployment handle. This handle and it's strap must be connected to the inner deployment bag of the parachute. If your harness does not have the proper handle, please contact your harness dealer.

The YETI rescue has a choice of 2 loops by which to attach the harness deployment handle. The choice of one or the other depends on the position of the rescue container in your harness. Front or back mounted rescue systems or when you use the outer container rescue are generally attached by the centre loop. Under seat mounted systems are attached by the loop at the side. THE CHOICE OF ATTACHMENT POINT DEPENDS ON THE HARNESS! If in doubt, consult with a professional.



Pre-flight checks

For maximum safety, use a complete and consistent system of pre-flight checks of your equipment and repeat the same mental sequence at *every* flight.

Specifically for the rescue, check that:

There is no visible damage that could affect its airworthiness.

The rescue parachute container is closed correctly with the pin(s) in place.

The deployment handle is secured correctly and all parts are in good condition. If any part of the harness/reserve/handle system include Velcro, then this must be separated and re-attached regularly to prevent Velcro 'bedding in' over time which can make rescue deployment much more difficult.

Rescue Deployment

It is vital to periodically feel the position of the rescue handle in normal flight, so that the action of reaching for the rescue is instinctive in an emergency.

In the event of an emergency, the pilot must quickly evaluate his or her height and the seriousness of the incident. On that basis, an instantaneous decision to deploy the rescue or not must be taken. Deploying the rescue when the glider is recoverable may increase the danger of injury. If you have sufficient height and the glider is in a flat spin, it is preferable to first try to stop the spin (e.g. full stall), due to the risk of entanglement. On the other hand, a second hesitation in deploying the reserve could prove costly if there is insufficient height.

Deployment Procedure

If the rescue is to be deployed, the procedure is as follows:

- 1- Look for the rescue handle and grasp it firmly with one hand.
- 2- Pull firmly upwards/sideways on the handle. This action undoes the Velcro or handle closure and allows the release pins to be pulled out of the release loops, so that the inner container can be released from the harness' rescue compartment.
- 3- Look for a clear area, and in a continuous motion, throw (and RELEASE!) the rescue as quickly and forcefully as possible away from yourself and the glider. Throwing the rescue in the direction of the air stream will speed opening, and throwing it against the direction of spin will help prevent tangling with the glider.
- 4- After deployment, avoid entanglement and pendulum motions by pulling in the glider as symmetrically as possible with the B, C, D or brake lines
- 5- On landing, be sure to do a PLF (Parachute Landing Fall) to minimize the risk of injury

- 6- Once on the ground, deflate the canopy by pulling one of the rescue lines to avoid the possibility of being dragged.



4. Care, Maintenance and Repairs

The YETI rescue should be repacked at least every 6 months, as detailed in the packing instructions. We always recommend that this rescue parachute is inspected and repacked by a trained professional repacker. Additional inspections should be performed if there is any suspicion of damage or undue wear.

After a deployment, the rescue should be checked by the distributor or manufacturer. Always seek professional advice whenever in doubt.

The materials used in the YETI rescue have been carefully selected for maximum durability. Nevertheless, maintaining your rescue following the guidelines below will extend its lifetime.

It is recommended that a rescue is replaced after 10 years, even if it has never been used.

Care and Maintenance

Unnecessary exposure to UV rays, heat and humidity should always be avoided. Keep your harness and rescue in your rucksack when not in use.

Store all your paragliding equipment in a cool, dry place, and away from solvents such as grease, acid, oil and paint.

Never put your rescue away while damp or wet.

If your rescue parachute does ever get wet (i.e. water landings or snow) you must remove it from the harness, dry it naturally in the air, and repack it before putting it back into the container.

A dirty rescue canopy or container can be cleaned with lukewarm water. Mild, neutral soap may be used if necessary, but do not rub the fabric. Rinse the canopy thoroughly and allow it to dry naturally. If the canopy shows signs of mildew or mould, it must be sent to the distributor or manufacturer for repairs, as the strength could be compromised.

If the rescue is to be stored for an extended period, the canopy should be opened and loosely rolled.

Repairs

Any repairs should only be carried out by the manufacturer or by an approved agent. This will ensure that the correct materials and repair techniques are used.

Re-packing card

Pilot Name:

Serial No. of the Rescue:

First Installation date:

Repacking Date	By	Signature

Every effort has been made to ensure that the information in this manual is correct, but please remember that it has been produced for guidance only. This owner's manual is subject to changes without prior notice. Please check www.gingliders.com for the latest information regarding the YETI rescue and other GIN products.

